

# 18" Variable Speed Scroll Saw (Model 40-650, Type 2)



DATED 11-25-98

PART NO. 1349463  
© Delta International Machinery Corp. 1998



TABLE OF CONTENTS	
SAFETY RULES.....	3
ADDITIONAL SAFETY RULES FOR SCROLL SAWS .....	4
UNPACKING AND CLEANING.....	5-6
ASSEMBLY INSTRUCTIONS.....	6
Assembling Stand .....	6
Fastening Scroll Saw To Stand .....	7
Assembling Rear Leg Height Extension .....	8
Assembling Holddown Foot .....	8
Rotating Table To 90 Degree Position .....	8
Assembling Table Insert .....	8
CONNECTING SCROLL SAW TO POWER SOURCE.....	9
Extension Cords .....	9
Grounding Instructions .....	9
FASTENING STAND TO SUPPORTING SURFACE.....	10
OPERATING CONTROLS AND ADJUSTMENTS	
On-Off Power Switch.....	10
Variable Speed Control .....	10
Locking On-Off Switch In The “OFF” Position .....	10
Dust Blower .....	11
Adjusting Blade Tension .....	11
Adjusting Clamping Action Of Blade Holders .....	12
Adjusting Holddown .....	12
Changing Blades .....	13
Tilting The Table.....	14
Adjusting 90 And 45 Degree Positive Stops For Table .....	14
Aligning Lower Blade Holder With Upper Blade Holder .....	15
Brush Inspection And Replacement .....	15
Fuse Replacement.....	16
BLADE BREAKAGE .....	16
CHOICE OF BLADE AND SPEED .....	16



# ADDITIONAL SAFETY RULES FOR SCROLL SAWS

1. **WARNING:** Do not operate your scroll saw until it is completely assembled and installed according to the instructions.
2. IF YOU ARE NOT thoroughly familiar with the operation of Scroll Saws, obtain advice from your supervisor, instructor or other qualified person.
3. YOUR SCROLL SAW STAND MUST be fastened to the floor if there is any tendency for the stand to move during operation.
4. THIS SCROLL SAW is intended for indoor use only.
5. MAKE SURE blade is properly tensioned before operating saw.
6. TO AVOID blade breakage ALWAYS adjust blade tension correctly.
7. MAKE SURE the blade teeth point downward toward the table.
8. NEVER turn the saw "ON" before clearing the table of all objects (tools, scraps of wood, etc.).
9. DO NOT cut material that is too small to be safely supported.
10. AVOID awkward hand positions where a sudden slip could cause a hand to move into the blade.
11. ALWAYS keep hands and fingers away from blade.
12. ALWAYS adjust holddown foot for each new operation.
13. DO NOT USE dull or bent blades.
14. DO NOT attempt to saw material that does not have a flat surface, unless a suitable support is used.
15. MAKE "relief" cuts before cutting long curves.
16. NEVER attempt to cut a curve that is too tight for the blade being used.
17. WHEN backing a blade out of a workpiece, the blade may bind in the saw kerf. This is usually caused by sawdust in the kerf. If this happens, turn "OFF" the switch and remove plug from power source outlet. Wedge open the kerf and back blade out of the workpiece.
18. ALWAYS hold the work firmly against the table.
19. DO NOT feed the material too fast while cutting.
20. NEVER start the Scroll Saw with the stock pressed against the blade.
21. WHEN cutting a large workpiece MAKE SURE the material is supported at table height.
22. USE CAUTION when cutting material which is irregular in cross section which could pinch the blade before the cut is completed. A piece of moulding for example must lay flat on the table and not be permitted to rock while being cut.
23. USE CAUTION when cutting round material such as dowel rods or tubing. They have a tendency to roll while being cut causing the blade to "bite." Use a V-block to control the piece.
24. ALWAYS release blade tension before loosening the blade holder.
25. MAKE CERTAIN table tilting lock is tightened before starting the machine.
26. NEVER reach under the table while the machine is running.
27. NEVER perform layout, assembly or set-up work on the table while the saw is operating.
28. ALWAYS STOP the saw before removing scrap pieces from the table.
29. SHOULD any part of your Scroll Saw be missing, damaged or fail in any way, or any electrical component fail to perform properly, shut off switch and remove plug from power supply outlet. Replace missing, damaged or failed parts before resuming operation.
30. ADDITIONAL INFORMATION regarding the safe and proper operation of this product is available from the National Safety Council, 1121 Spring Lake Drive, Itasca, IL 60143-3201, in the Accident Prevention Manual for Industrial Operations and also in the Safety Data Sheets provided by the NSC. Please also refer to the American National Standards Institute ANSI O1.1 Safety Requirements for Woodworking Machinery and the U.S. Department of Labor OSHA 1910.213 Regulations.
31. SAVE THESE INSTRUCTIONS. Refer to them frequently and use them to instruct other users.

# UNPACKING AND CLEANING

Your new scroll saw and stand is shipped complete in one container. Carefully unpack the saw, stand and all loose items from the shipping container. Figure 2 illustrates the saw and all loose items and Figure 3 illustrates the stand and all related parts. Remove the protective coating from the saw table surface. This coating may be removed with a soft cloth moistened with kerosene (do not use acetone, gasoline or lacquer thinner for this purpose). After cleaning, cover the table surface with a good quality paste wax. Buff out the wax thoroughly to prevent it from rubbing into your workpieces.

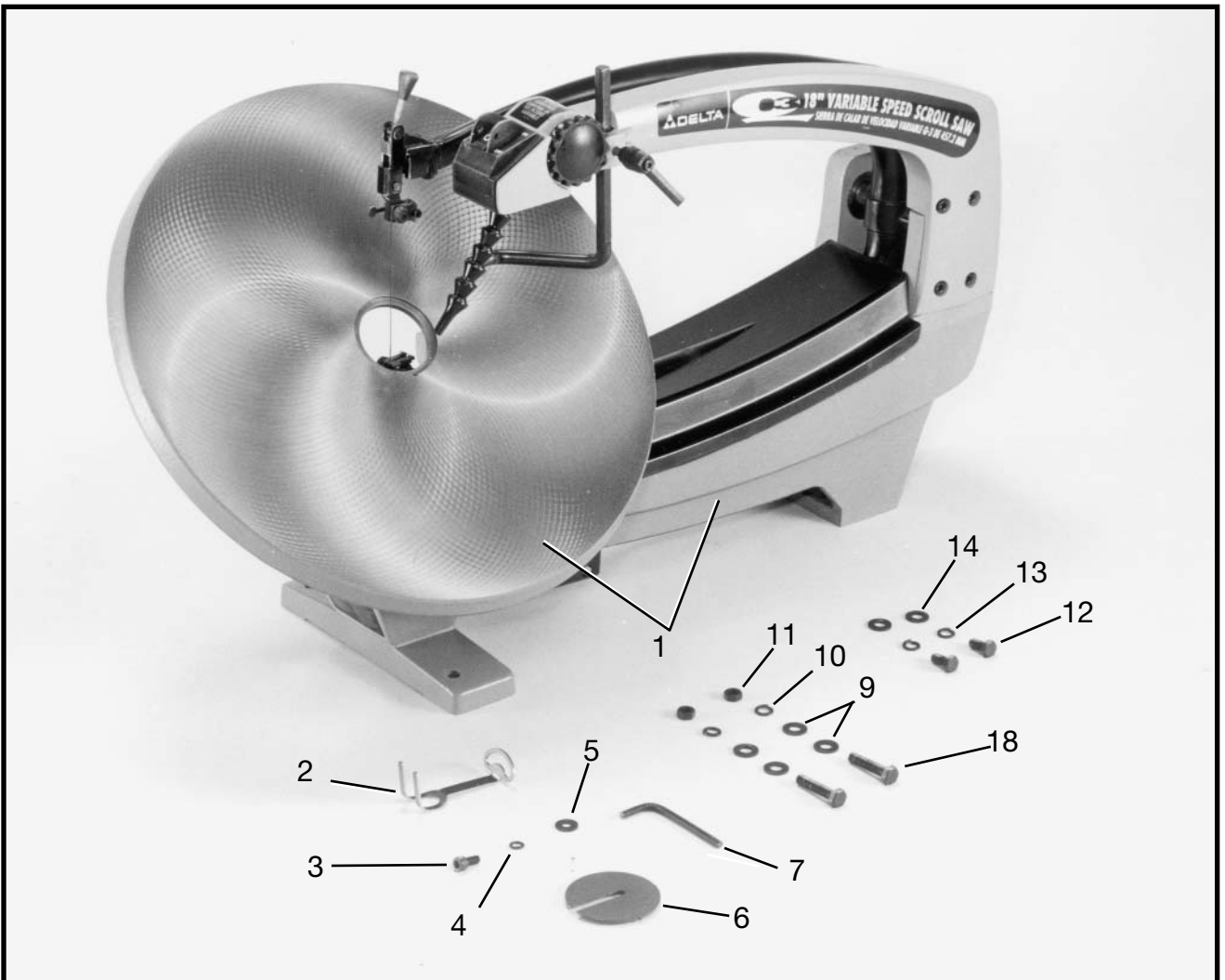

Fig. 2

- 1 - Scroll Saw
- 2 - Holddown Foot
- 3 - 1/2" Long Hex Socket Head Screw - for fastening holddown foot to rod
- 4 - Lockwasher - for fastening holddown foot to rod
- 5 - Flat Washer - for fastening holddown foot to rod
- 6 - Table Insert
- 7 - 5mm Wrench
- 8 - 1-1/2" Long Hex Head Screws - for fastening front of saw to stand (2)

- 9 - Flat Washers - for fastening front of saw to stand (4)
- 10 - Lockwashers - for fastening front of saw to stand (2)
- 11 - Hex Nuts - for fastening front of saw to stand (2)
- 12 - 5/8" Long Hex Head Screws - for fastening rear of saw to stand (2)
- 13 - Lockwashers - for fastening rear of saw to stand (2)
- 14 - Flat washers - for fastening rear of saw to stand (2)

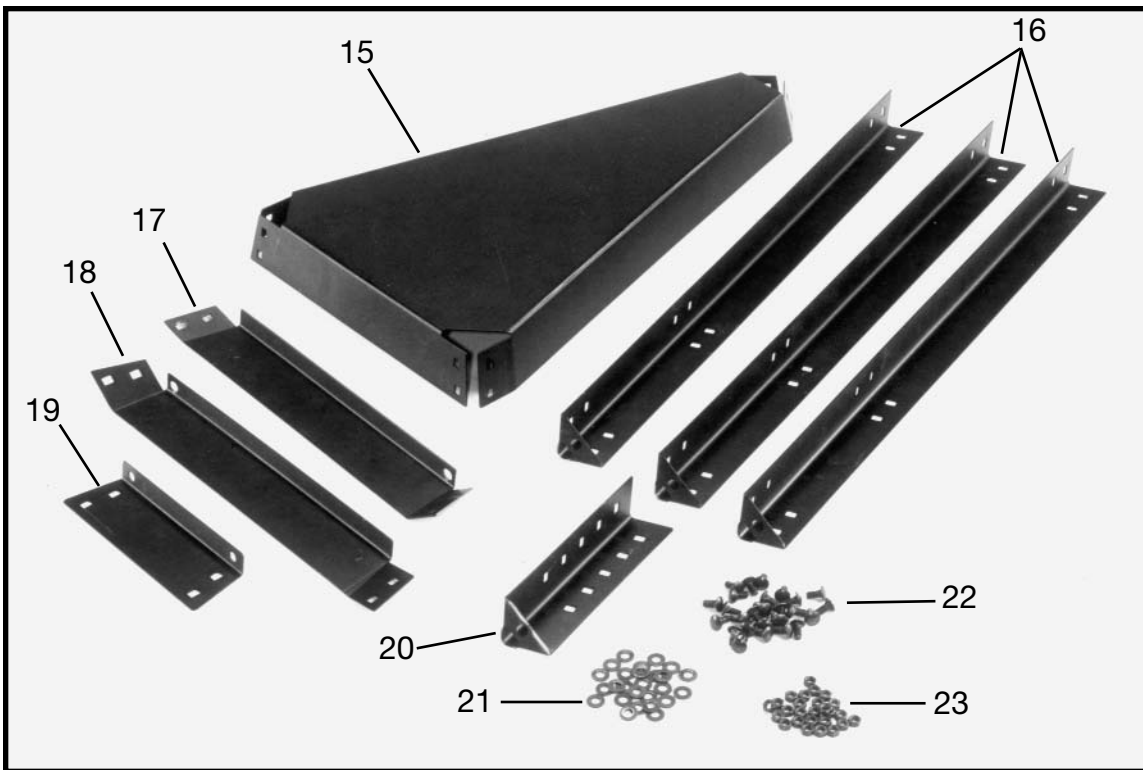

Fig. 3

- 15 - Bottom Shelf
- 16 - Legs (3)
- 17 - Left Top Brace
- 18 - Right Top Brace
- 19 - Front Top Brace

- 20 - Height Adjustment Bracket for rear leg
- 21 - Flat Washers (28)
- 22 - 5/8" long (8mm) Carriage Bolts (28)
- 23 - Hex Nuts (28)

## ASSEMBLY INSTRUCTIONS

**WARNING: FOR YOUR OWN SAFETY, DO NOT CONNECT THE SCROLL SAW TO THE POWER SOURCE UNTIL THE MACHINE IS COMPLETELY ASSEMBLED AND YOU HAVE READ AND UNDERSTOOD THE ENTIRE OWNERS MANUAL.**

### ASSEMBLING STAND

1. Assemble the stand, as shown in Fig. 4, using the 24 carriage bolts, flat washers and hex nuts. NOTE: The round holes on the top of the two top braces (A) are to be positioned toward the rear leg (B) and all three legs are positioned outside the bottom shelf and top braces. DO NOT TIGHTEN STAND MOUNTING HARDWARE AT THIS TIME.

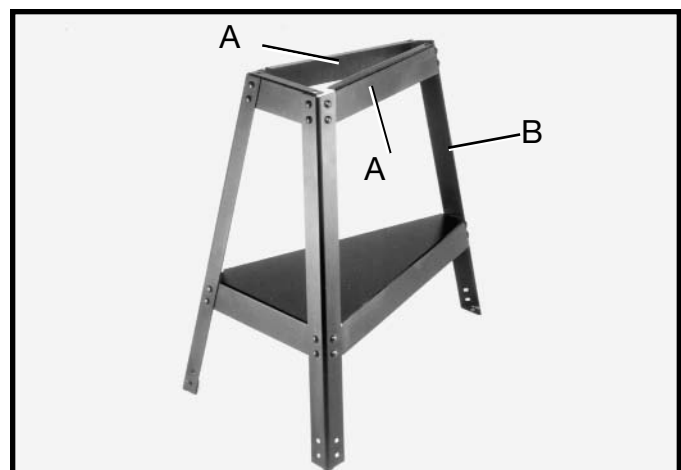

Fig. 4

## FASTENING SCROLL SAW TO STAND

1. Place scroll saw on top braces of stand and fasten front of saw to top front brace using the two 1-1/2" long screws (A) Fig. 5, flat washers (B) and two flat washers (C), lock washers (D) and hex nuts (E) from below.

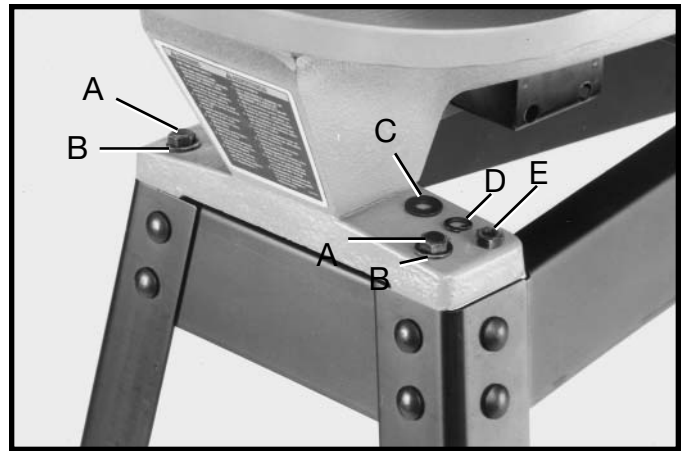

Fig. 5

2. Fasten the rear of the saw to the stand using the two 5/8" long screws (F) Fig. 6, and lock washers (G). The 5/8" long screws (F) are also shown in Fig. 7, and are threaded up into the threaded holes located on bottom of saw base.

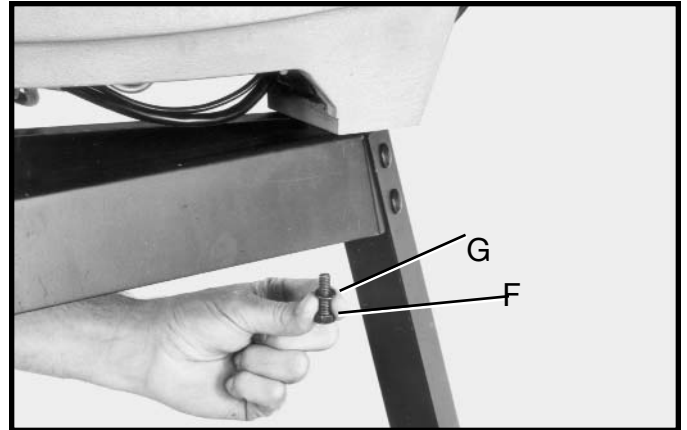

Fig. 6

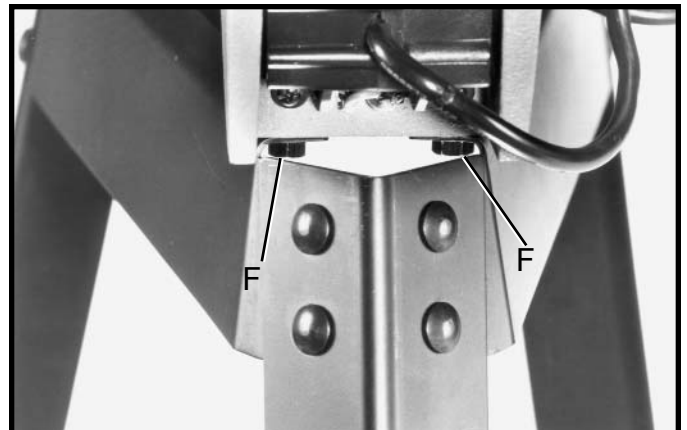

Fig. 7

3. Figure 8 illustrates the saw (H) fastened to the stand (J). Place the stand on a level surface and securely tighten all stand mounting hardware.

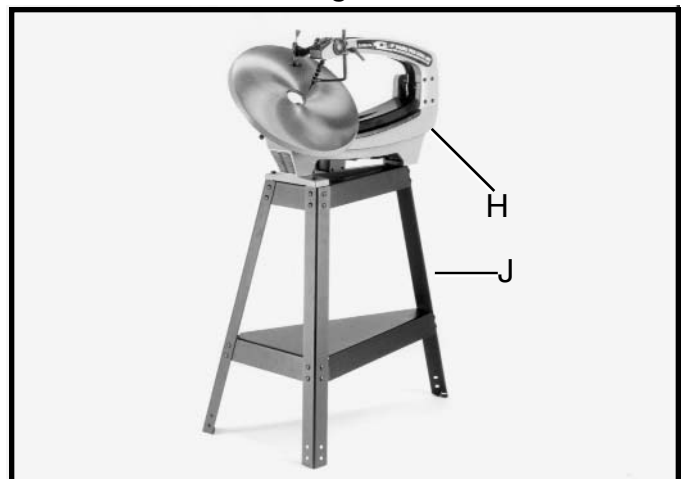

Fig. 8

## ASSEMBLING REAR LEG HEIGHT EXTENSION

1. A height extension (A) Fig. 9, is supplied with your stand and can be assembled to the rear leg of the stand, as shown, using the four carriage bolts (B), flat washers and nuts supplied. The height extension enables you to tilt the saw forward during operation if desired. Five holes are supplied in the extension (A) to vary the degree of tilt.

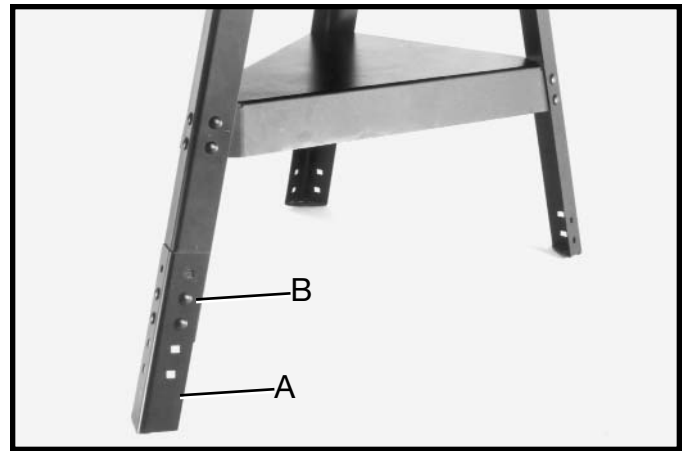

Fig. 9

## ASSEMBLING HOLDDOWN FOOT

1. With wrench supplied, assemble holddown foot (A) Fig. 10, to rod (B) using 1/2" hex socket head screw (C) with lockwasher and flat washer. Prongs of holddown foot (A) should straddle blade.

2. Adjustment to holddown rod (B) Fig. 10, can be made by loosening lock handle (D) and raising or lowering rod (B). Tighten lock handle (D). NOTE: Lock handle (D) Fig.10, is spring-loaded and can be repositioned by pulling outward on the handle and repositioning it on the stud located underneath the hub of handle (D).

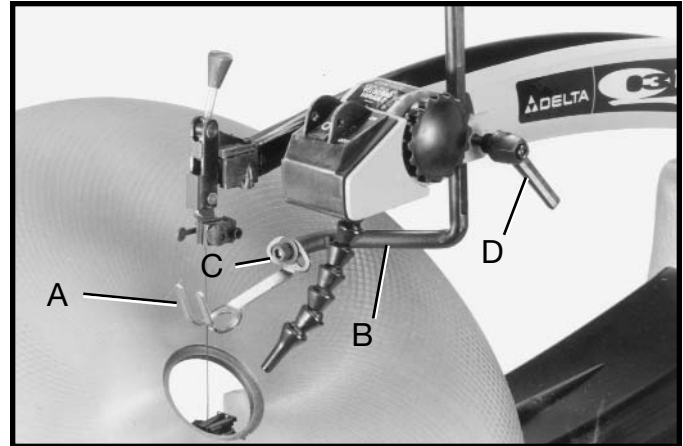

Fig. 10

## ROTATING TABLE TO 90 DEGREE POSITION

1. The saw is shipped with the table tilted 45 degrees to the right, as shown in Fig. 11. To move the table to the 90 degree position, loosen lock handle (A) and rotate table all the way to the left. Then tighten lock handle (A). NOTE: Lock handle (A) is spring-loaded and can be repositioned by pulling out the handle and repositioning it on the stud located underneath the hub of the handle.

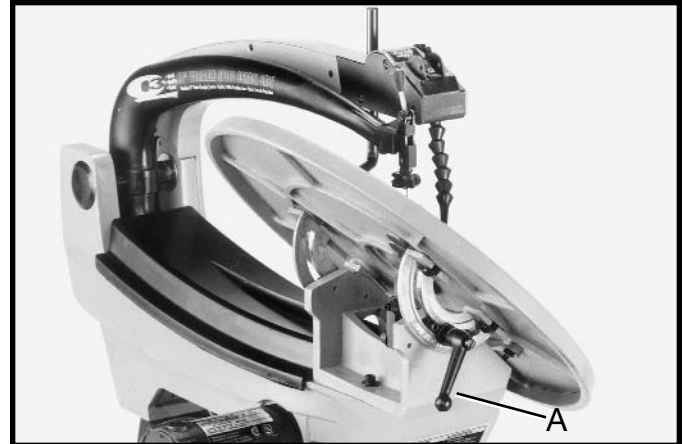

Fig. 11

2. Fig. 12 illustrates the table (B) in the 90 degree position.

## ASSEMBLING TABLE INSERT

1. Assemble the table insert (C) Fig. 12, to opening in the center of the table (B) as shown.

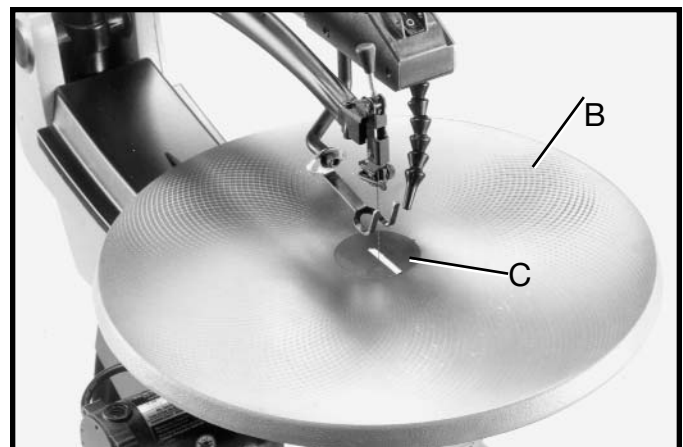

Fig. 12



# CONNECTING SCROLL SAW TO POWER SOURCE

**IMPORTANT:** BEFORE CONNECTING THE SAW TO THE POWER LINE, MAKE SURE THE SWITCH IS IN THE “OFF” POSITION.

## EXTENSION CORDS

The use of any extension cord will cause some loss of power. To keep this loss to a minimum, make sure the extension cord is in good condition and is a 3-wire extension cord which has a 3-prong grounding type plug and a 3-pole receptacle which will accept the tool’s plug. When using an extension cord, be sure to use one heavy enough to carry the current of the scroll saw. An undersized cord will cause a drop in line voltage resulting in loss of power and overheating. Fig. 13, shows the correct size to use depending on cord length. If in doubt, use the next heavier gage. The smaller the gage number, the heavier the cord.

EXTENSION CORD SIZE		
LENGTH OF EXTENSION CORD IN FEET		120 VOLT WIRE SIZE REQUIRED (AWG - American Wire Gage)
0	- 25	18 AWG
26	- 50	16 AWG
51	- 100	16 AWG
101	- 150	14 AWG

Fig. 13

## GROUNDING INSTRUCTIONS

**CAUTION: THIS TOOL MUST BE GROUNDED WHILE IN USE TO PROTECT THE OPERATOR FROM ELECTRIC SHOCK.**

In the event of a malfunction or breakdown, grounding provides a path of least resistance for electric current to reduce the risk of electric shock. This tool is equipped with an electric cord having an equipment-grounding conductor and a grounding plug. The plug must be plugged into a matching outlet that is properly installed and grounded in accordance with all local codes and ordinances.

Do not modify the plug provided - if it will not fit the outlet, have the proper outlet installed by a qualified electrician.

Improper connection of the equipment-grounding conductor can result in risk of electric shock. The conductor with insulation having an outer surface that is green with or without yellow stripes is the equipment-grounding conductor. If repair or replacement of the electric cord or plug is necessary, do not connect the equipment grounding conductor to a live terminal.

Check with a qualified electrician or service personnel if the grounding instructions are not completely understood, or if in doubt as to whether the tool is properly grounded.

Use only 3-wire extension cords that have 3-prong grounding type plugs and 3-hole receptacles that accept

the tool's plug, as shown in Fig. 14.

Repair or replace damaged or worn cord immediately. If a properly grounded outlet is not available, a temporary adapter, shown in Fig. 15, may be used for connecting the 3-prong grounding type plug to a 2-prong receptacle. The temporary adapter should be used only until a properly grounded outlet can be installed by a qualified electrician. The green colored rigid ear, lug, or the like extending from the adapter must be connected to a permanent ground such as a properly grounded outlet box cover. Whenever the adapter is used, it must be held in place with a metal screw.

**NOTE: In Canada, the use of a temporary adapter is not permitted by the Canadian Electric Code.**

**CAUTION: IN ALL CASES, MAKE CERTAIN THE RECEPTACLE IN QUESTION IS PROPERLY GROUNDED. IF YOU ARE NOT SURE, HAVE A CERTIFIED ELECTRICIAN CHECK THE RECEPTACLE.**

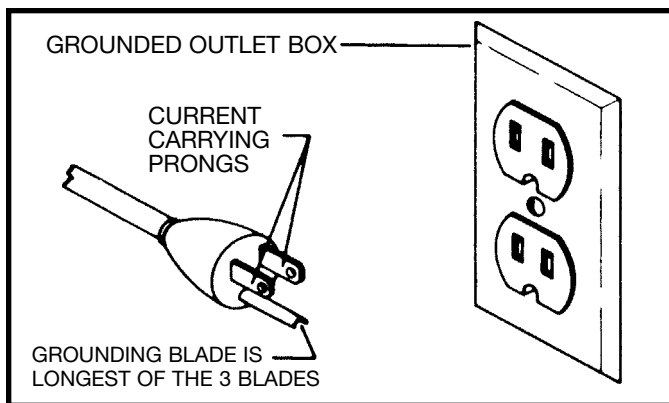

Fig. 14

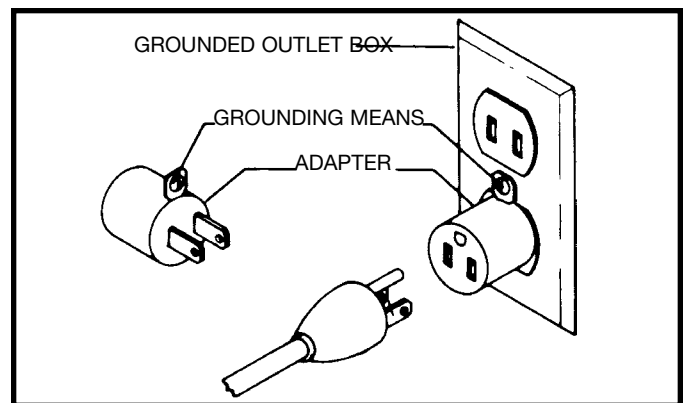

Fig. 15

## FASTENING STAND TO SUPPORTING SURFACE

If there is any tendency for the scroll saw to move during operation, the scroll saw stand must be fastened to the floor.

## OPERATING CONTROLS AND ADJUSTMENTS

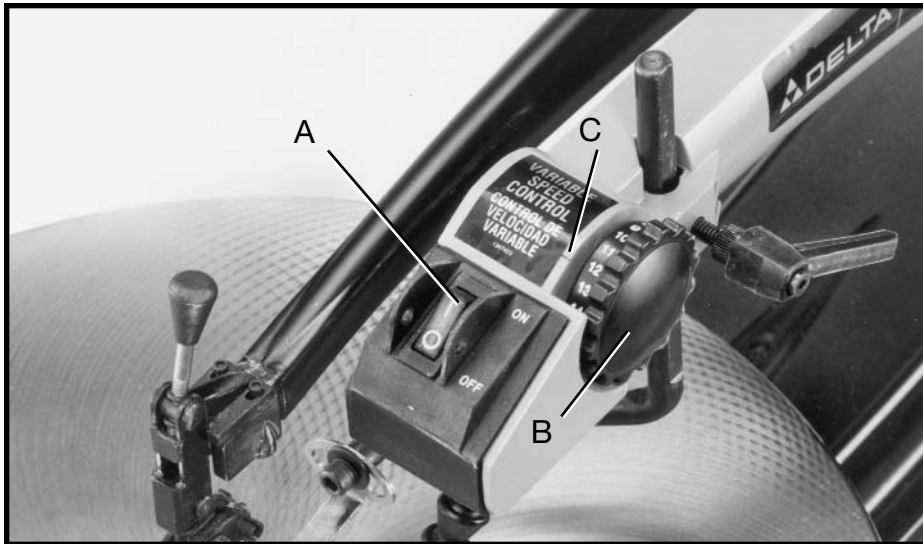

Fig. 16

### ON-OFF POWER SWITCH

The on-off switch (A) Fig. 16, is located on the top of the arm, as shown. To turn the saw "ON" push down on the "ON" portion of the switch and to turn the saw "OFF" push down on the "OFF" portion of the switch.

### VARIABLE SPEED CONTROL

Your scroll saw can be operated at speeds of 300 to 2000 cutting strokes per minute by rotating control knob (B) Fig. 16. With the control knob (B) rotated all the way toward the front of the machine the speed will be 300 cutting strokes per minute and with the control knob (B) rotated all the way to the rear, the speed will be 2000 cutting strokes per minute. A series of numbers are provided on the control knob, as shown, and a witness line (C) is provided on the arm to be used for reference.

### LOCKING ON-OFF SWITCH IN "OFF" POSITION

**IMPORTANT:** We suggest that when the scroll saw is not in use, the on-off switch be locked in the "OFF" position using a padlock (A), as shown in Fig. 17. Available as an accessory from Delta is the 50-325 padlock, shown at (A).

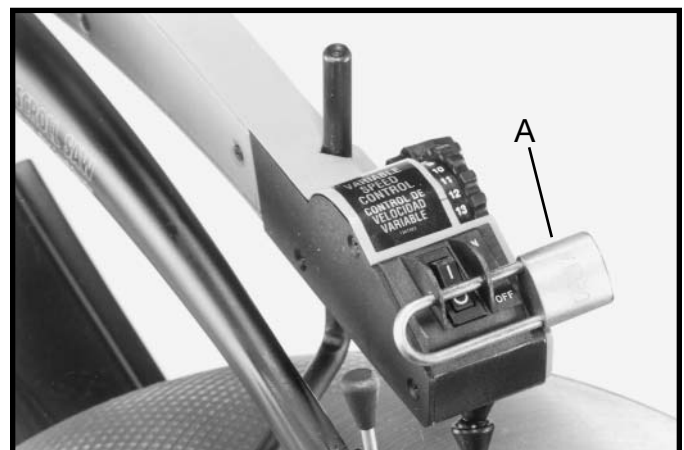

Fig. 17

## DUST BLOWER

A dust blower (A) Fig. 18, is provided, and can be moved to direct air to the most effective point on the cutting line.

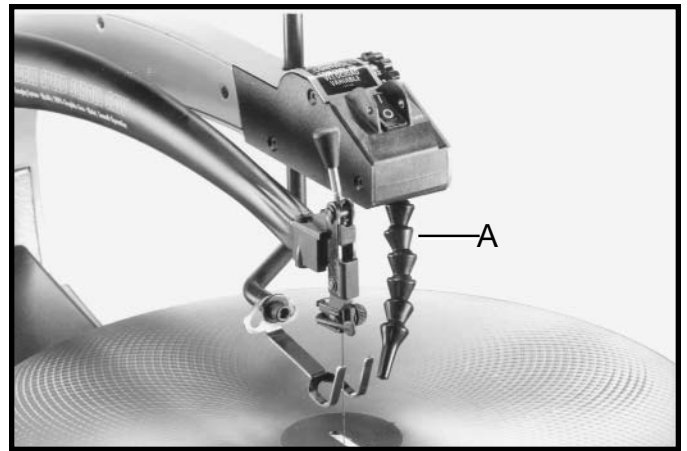

Fig. 18

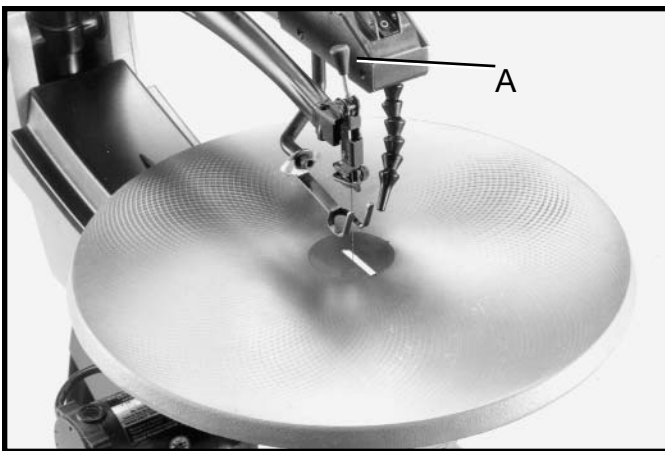

Fig. 19



Fig. 20

## ADJUSTING BLADE TENSION

Tension is applied to the blade when the blade tension lever (A) Fig. 19, is in the rear position, as shown. When the lever (A) is moved forward, as shown in Fig. 20, blade tension is released.

To increase tension on the blade, rotate tension lever (A) Fig. 20, clockwise; to decrease blade tension, rotate tension lever counterclockwise. NOTE: When adjusting blade tension, the lever (A) Fig. 20, should be in the full forward position. It is only necessary to adjust blade tension knob when a different type of blade is assembled to the blade holders. It is not necessary to adjust blade tension when the blade is removed from and replaced in only the upper blade holder, as in performing inside cutting operations. Adjusting proper tension on the blade is usually accomplished by trial and error; however, a good method to use is to pluck the rear of the blade like guitar string after the tension lever is moved to the rear. A high-pitched tone of the blade usually indicates proper tension. Thicker blades require more tension (a higher pitched sound) while finer blades require less tension.

## ADJUSTING CLAMPING ACTION OF BLADE HOLDERS

Different widths of scroll saw blades will make it necessary to adjust the clamping action of the blade holders. It should be noted, however, that very little adjustment is necessary and very little clamping force is required to hold the blade satisfactorily. As a rule of thumb, looking down at the table with the table insert slot in the 6 o'clock position, resistance on the blade locking lever should be felt when the upper blade locking lever reaches the 7 o'clock position, or when the lower blade locking lever reaches the 5 o'clock position.

1. Move the blade holder clamping lever (A) Fig. 21, to the rear (open) position as shown.
2. Turn adjustment knob (B) Fig. 21, clockwise to tighten or counterclockwise to loosen the clamping action on the blade holder. NOTE: Very little movement of the knob (B) is necessary to make the adjustment.



Fig. 21

3. Move lever (A) Fig. 22, forward after adjusting the blade clamping action.
4. Adjust clamping action on lower blade holder in the same manner.

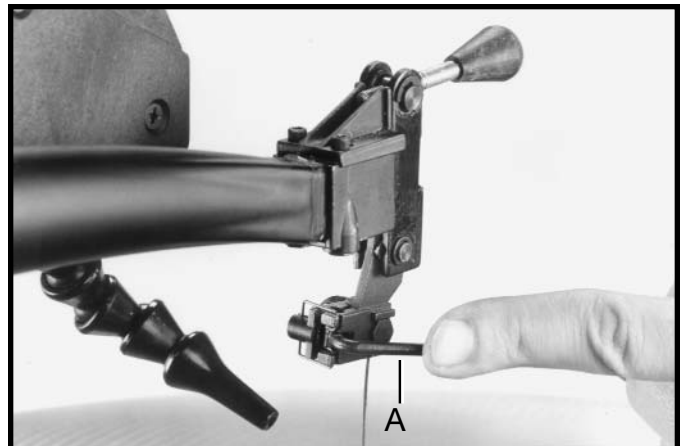

Fig. 22

## ADJUSTING HOLDDOWN

1. The holddown (A) Fig. 23, should be adjusted so it contacts the top surface of the work being cut by loosening lock handle (B) and moving holddown rod (C) up or down. Then tighten lock handle (B).

2. When bevel cutting (table tilted), the holddown (A) Fig. 23, can be tilted to match the angle of the table by loosening screw (D), tilting holddown (A) and tightening screw (D).

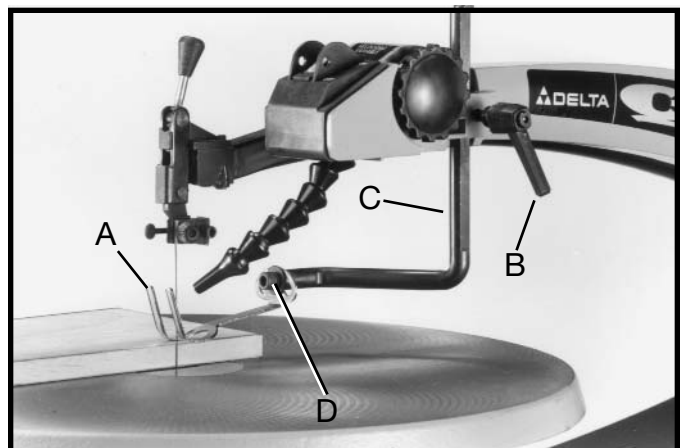

Fig. 23

## CHANGING BLADES

1. **WARNING: TO AVOID INJURY FROM ACCIDENTAL STARTING, ALWAYS TURN SWITCH "OFF" AND REMOVE POWER CORD PLUG FROM ELECTRICAL OUTLET BEFORE REMOVING OR REPLACING BLADE.**

2. Remove table insert (A) Fig. 24, and release blade tension by pulling tension lever (B) forward, as shown.

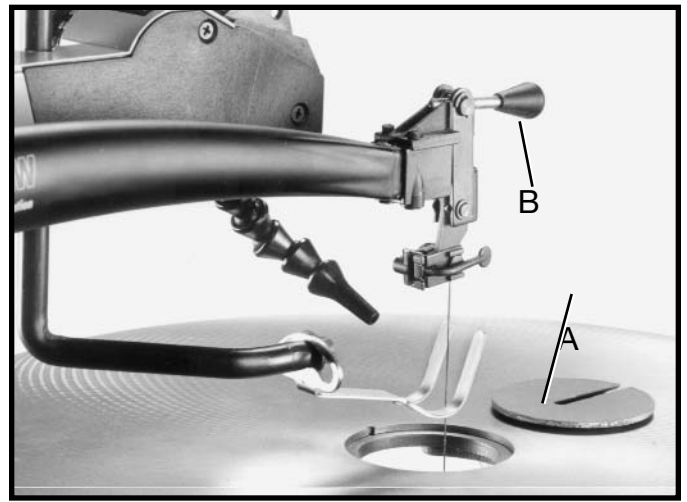

Fig. 24

3. Push blade holder clamping lever (C) Fig. 25, to the rear as shown. This will automatically release the blade (D) from the upper blade holder (E).

4. Push lower blade holder clamping lever (F) Fig. 26, to the rear. This will automatically release blade (D) from lower chuck.

5. Remove blade from lower chuck.

6. Insert new blade into the lower and upper blade holders in the same manner, making certain the blade teeth are pointing down toward the table.

7. Apply blade tension by referring to section, "ADJUSTING BLADE TENSION." NOTE: NEVER push down on blade tension knob (B) Fig. 25, to compress tension spring.

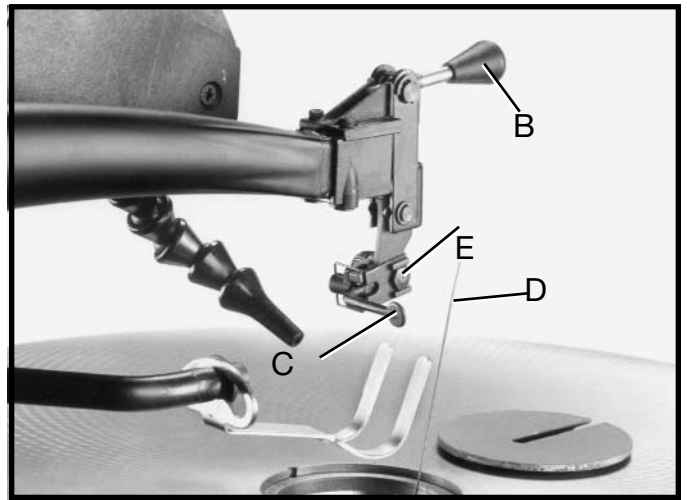

Fig. 25

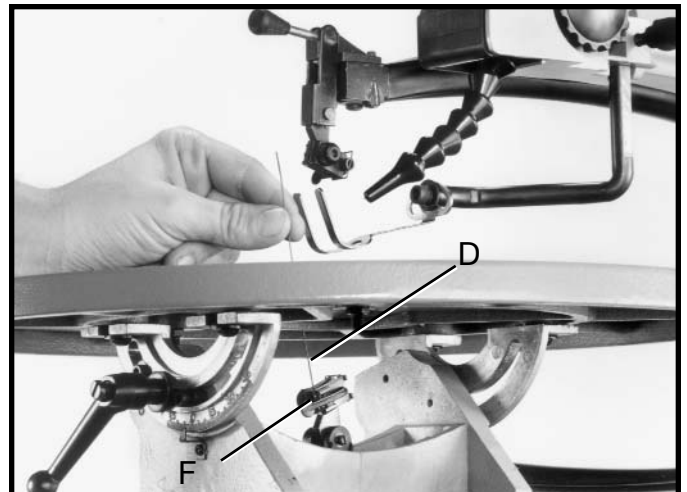

Fig. 26

## TILTING THE TABLE

1. The table on your scroll saw can be tilted up to 45 degrees to the right for bevel cutting operations by loosening table lock handle (A) Fig. 27. Tilt the table to the desired angle and tighten lock handle (A). A scale and pointer (B) Fig. 27, is provided to determine the angle of tilt.
2. The table can also be tilted up to 15 degrees to the left for bevel cutting operations by lowering the stop block (C) Fig. 27, and tilting the table to the desired angle, as shown in Fig. 28. Tighten lock handle (A).

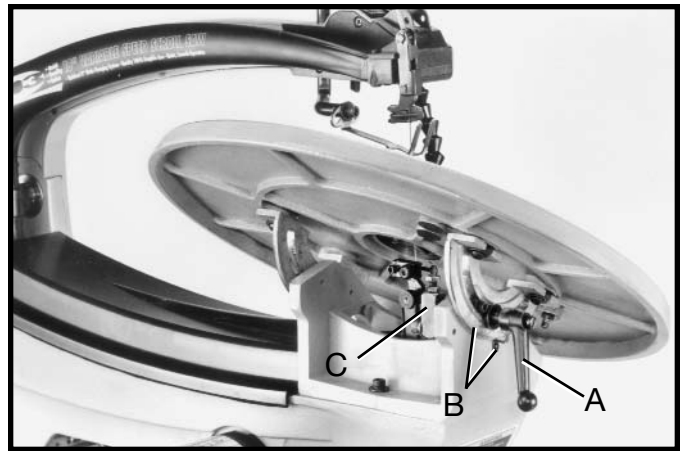

Fig. 27

## ADJUSTING 90 AND 45 DEGREE POSITIVE STOPS FOR TABLE

1. Loosen table lock handle and move the table all the way to the left and tighten table lock handle.
2. Using a square (A) Fig. 29, check to see if the table is 90 degrees to the saw blade, as shown.
3. If the table is not at 90 degrees to the blade, adjust the table accordingly, making certain screw (B) Fig. 30, contacts bottom of table surface when table is 90 degrees to the blade. Screw (B) can be adjusted by loosening nut (C), thread screw (B) in or out the desired distance and tighten nut (C).
4. Tilt table all the way to the right, as shown in Fig. 31, and tighten table lock handle.
5. Using a square (D) Fig. 31, check to see if the table is 45 degrees to the saw blade, as shown.
6. If the table is not at 45 degrees to the blade, adjust the table accordingly, making certain screw (E) Fig. 30, contacts side of base when the table is at 45 degrees to the blade.

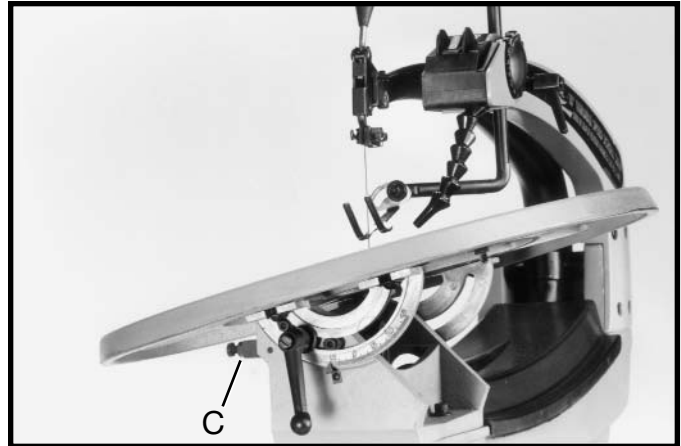

Fig. 28

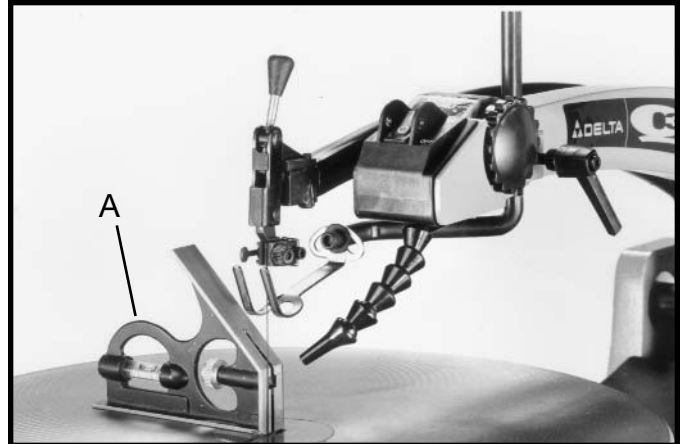

Fig. 29

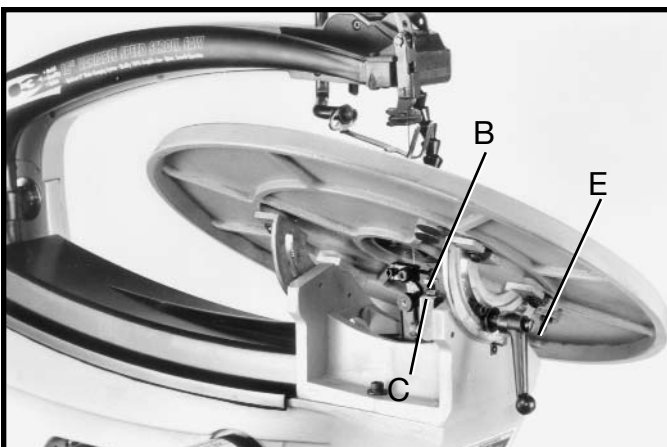

Fig. 30

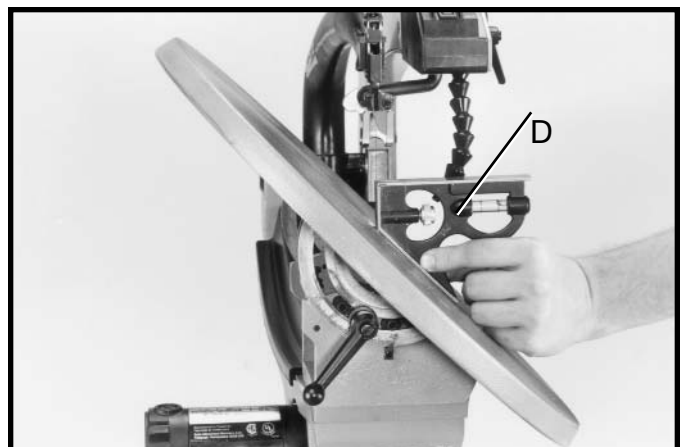

Fig. 31

## ALIGNING LOWER BLADE HOLDER WITH UPPER BLADE HOLDER

The lower blade holder has been aligned with the upper blade holder at the factory and further alignment should not be necessary; however, to check or adjust the alignment, proceed as follows:

1. **MAKE CERTAIN THE MACHINE IS DISCONNECTED FROM THE POWER SOURCE.**
2. Remove the table insert and place a small straight edge (A) Fig. 32, against the side of the saw blade (B) as shown in Fig. 32.
3. While holding the straight edge (A) Fig. 32, against the saw blade, carefully move the cutting arm (E) up and down in a cutting motion. **CAUTION:** Do not use excessive force on the cutting arm. The saw blade should contact the straight edge during the entire cutting stroke.
4. If an alignment is necessary, rotate adjustment screw (C) Fig. 33, to move the lower blade holder (D) left or right, until the saw blade is in consistent contact with the straight edge during the entire cutting stroke.

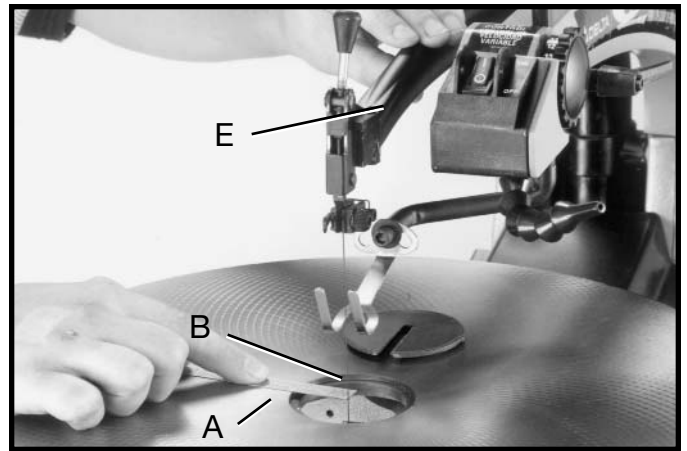

Fig. 32

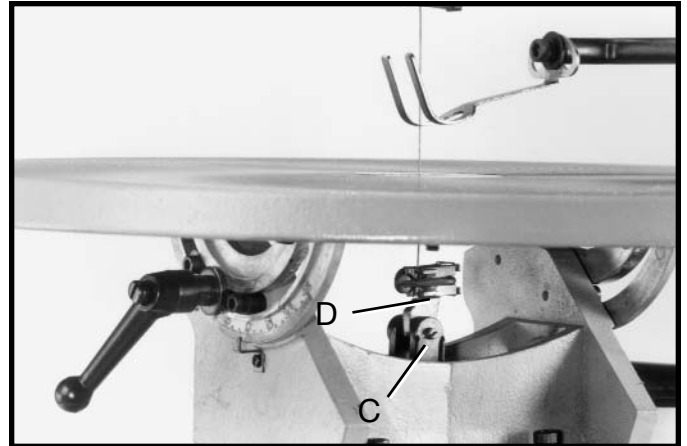

Fig. 33

## BRUSH INSPECTION AND REPLACEMENT

**CAUTION: BEFORE INSPECTING THE BRUSHES, DISCONNECT THE MACHINE FROM THE POWER SOURCE.**

Brush life varies. It depends on the load on the motor. Check the brushes after the first 50 hours of use for a new machine or after a new set of brushes has been installed. After the first check, examine them after about 10 hours of use until such time that replacement is necessary.

The brush holders, one of which is shown at (A) Fig. 34, are located in the motor housing opposite each other. Fig. 35 illustrates one of the brushes removed for inspection. When the carbon (B) on either brush is worn to 3/16" in length or if either spring (C) or shunt wire is burned or damaged in any way, replace both brushes. If the brushes are found serviceable after removing, reinstall them in the same position as removed.

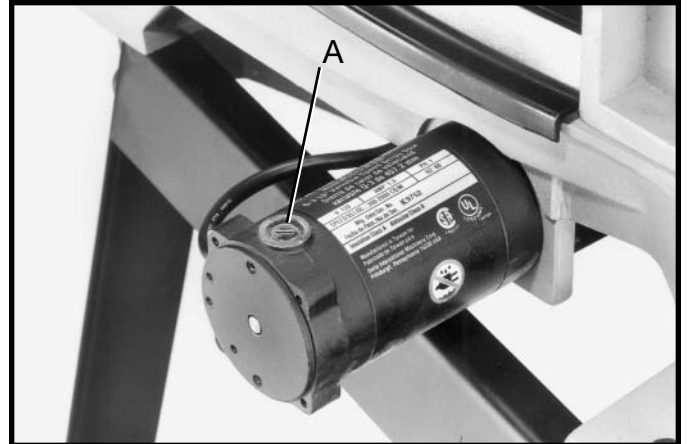

Fig. 34

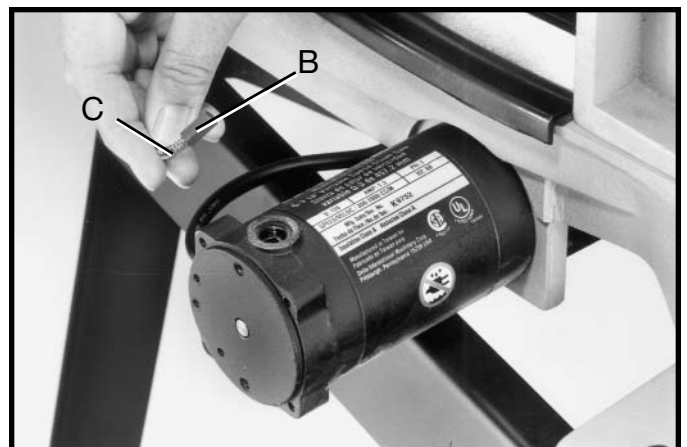

Fig. 35

## FUSE REPLACEMENT

A fuse holder (A) Fig. 36, and fuse (B) are located up under the rear of the machine and should be removed and checked if the machine does not operate. If the fuse (B) is bad, replace it with a 4 amp fuse.

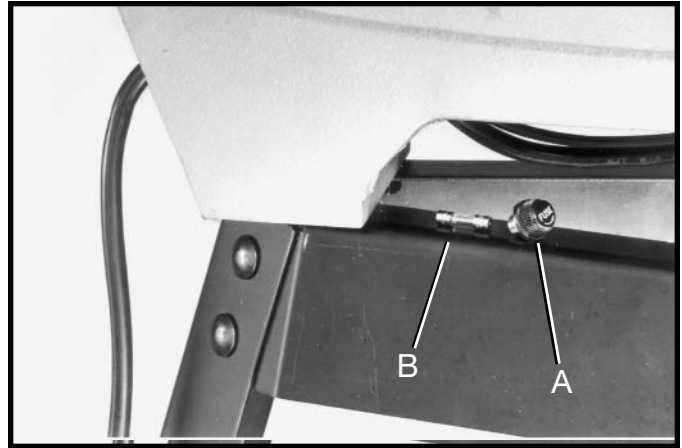

Fig. 36

---

## BLADE BREAKAGE

Blade breakage is usually caused by one or more of the following:

1. Bending the blade during installation.
2. Improper blade tension.
3. Improper blade selection for the work being cut.
4. Forcing the work into the blade too rapidly.
5. Cutting too sharp a turn for the blade being used.
6. Improper blade speed.

---

## CHOICE OF BLADE AND SPEED

Your scroll saw will accept a wide variety of 5" flat end blades and can be operated at any speed from 300 to 2000 cutting strokes per minute. Consider the following as a general guideline for selecting a blade and operating speed.

1. Use a finer blade for cutting thin workpieces, for hard materials, or when a smoother cut is required.
2. Use a coarser blade for cutting thick workpieces, when making straight cuts or for medium to soft materials.
3. Use a blade that will have 2 teeth in the workpiece at all times.
4. Most blade packaging is marked with the size of the wood the blade is intended to cut and the minimum radius which can be cut with that blade.
5. Slower speeds are generally more effective than faster speeds when using thin blades and making intricate cuts.
6. Always start at a slow speed and gradually increase the speed until the optimum cutting speed is obtained.